

Name:

Teacher Assessment

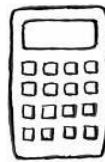

Section A **Solids** **Grade E**

1. Write down the name of each of these 3-D shapes,

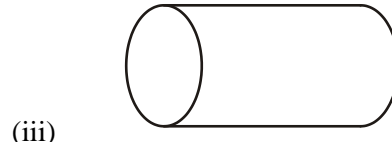
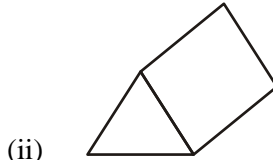
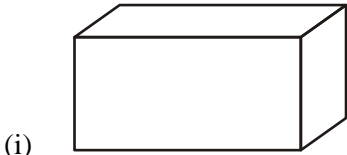

Answer (i)

(ii)

(iii)

(Total 3 marks)

2. (a) On the isometric grid complete the drawing of a cuboid 4 cm by 3 cm by 2 cm.

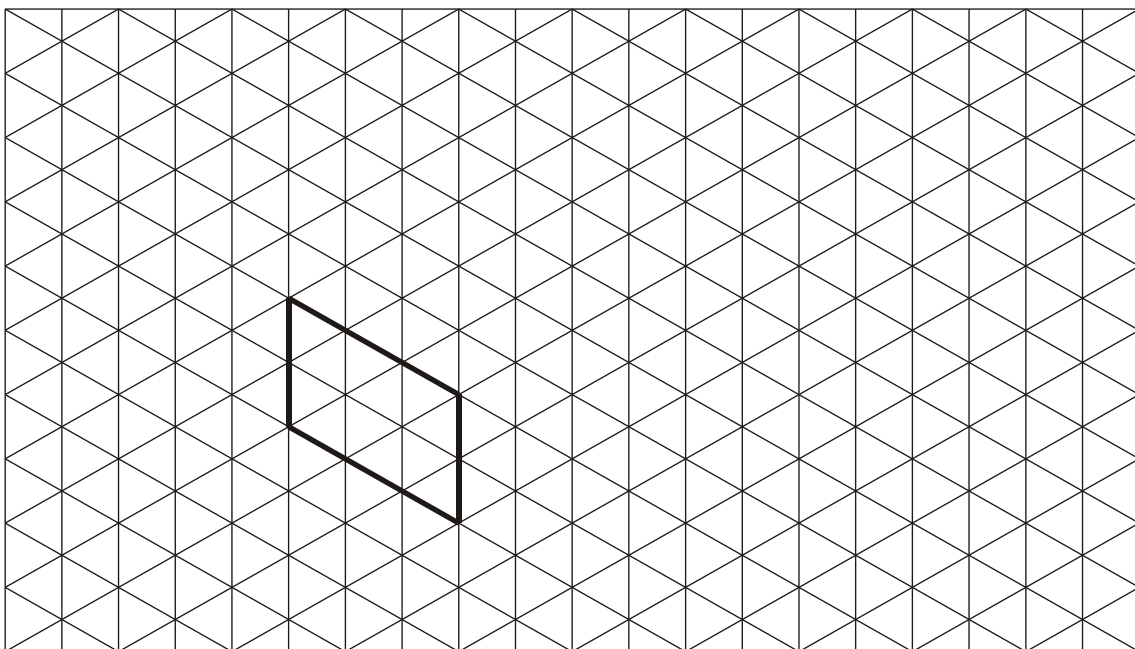

(2)

(b) Calculate the volume of the cuboid.

.....

.....

Answer cm³

(2)(Total 4 marks)

Success:

Target:

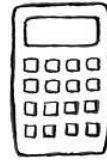

Section B

Plans and Elevations

Grade D

1. The diagram shows a prism with an L-shaped cross section.

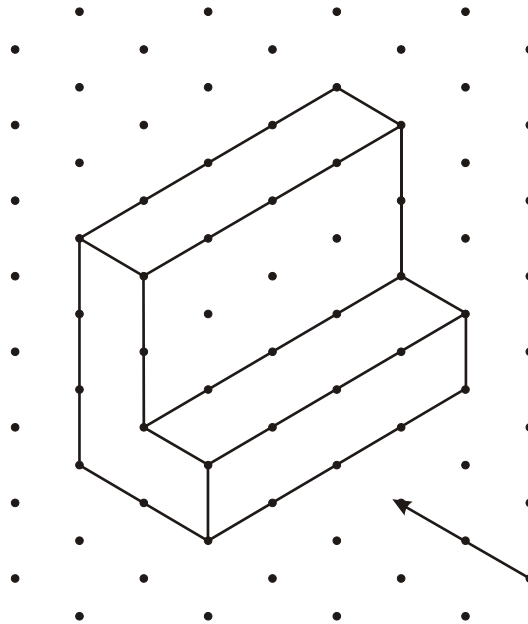

On the grid below, draw the elevation of this solid, from the direction shown by the arrow.

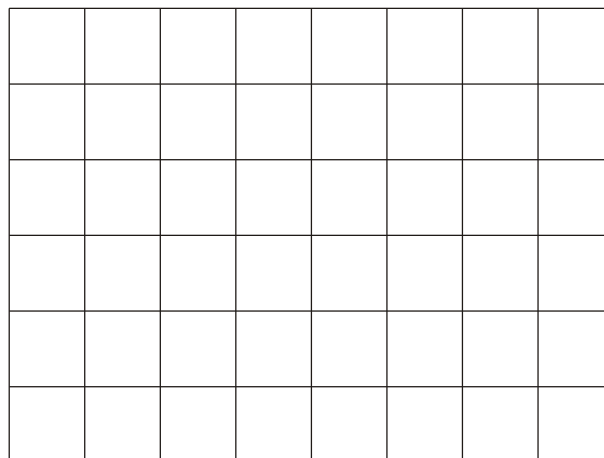

(Total 2 marks)

2. The diagram represents a solid made from 9 small cubes.

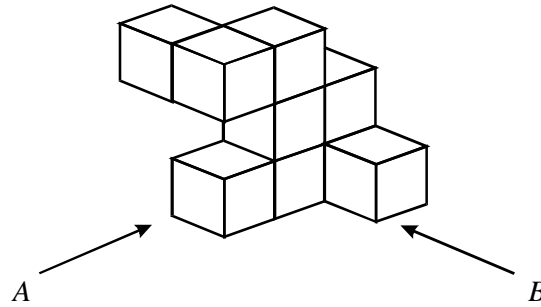

The view of the solid from direction *A* is shown below.

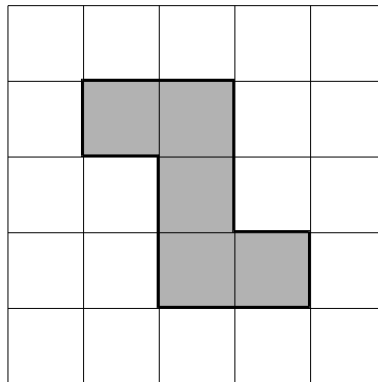

On the grid below, draw the view of the solid from direction *B*.

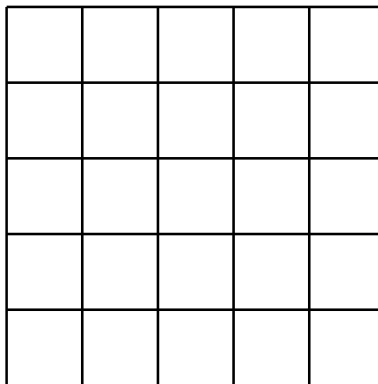

(Total 2 marks)

3.

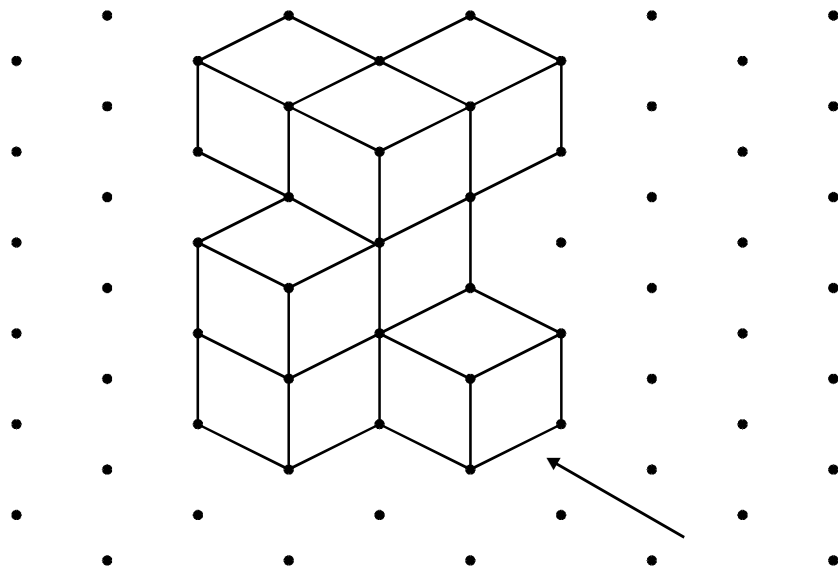

On the grid below, draw and shade in the elevation of the solid from the direction shown by the arrow.

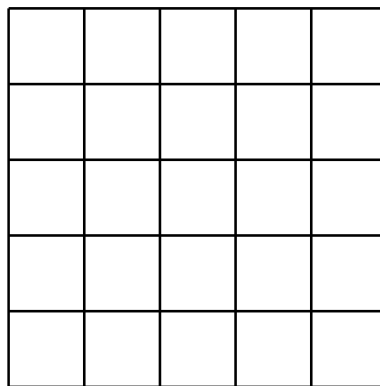

(Total 2 marks)

4. This 3-D shape is made from seven cubes.
It is drawn on an isometric grid.

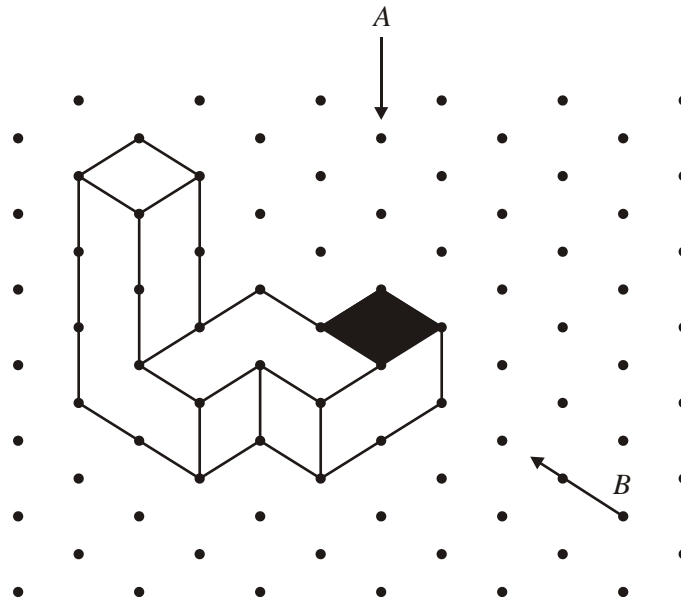

- (a) Tim looks down on the shape from *A*.
One of the faces of a cube that he sees is shaded.
Shade all the other faces that he sees.

(1)

- (b) On this grid draw the plan from *A*.

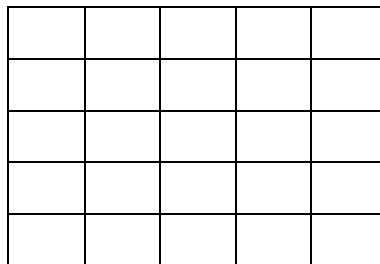

(1)

- (c) On this grid draw the front elevation from *B*.

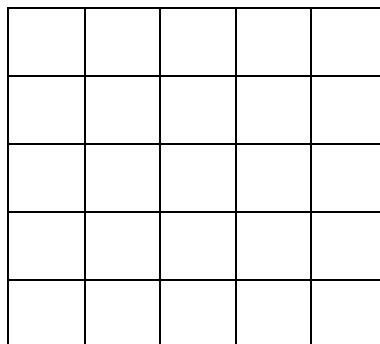

(1)
(Total 3 marks)

5. The diagram shows a solid shape made from 8 cubes.

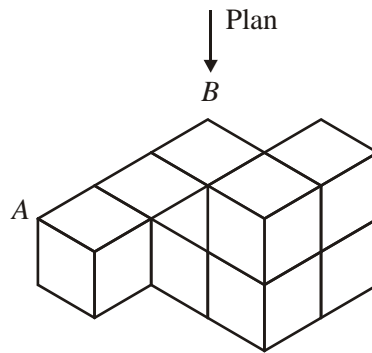

Complete the plan view of the shape on the grid below.

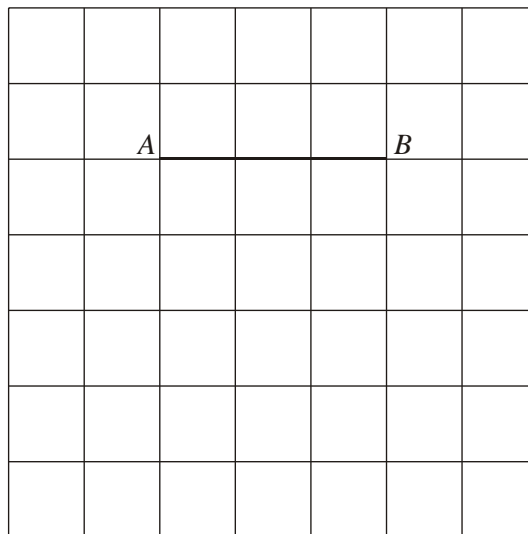

(Total 2 marks)

Success:

Target:

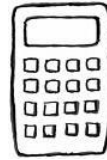

Section C

Nets

Grade F / E

1. Which **three** of the following are nets of a cube?

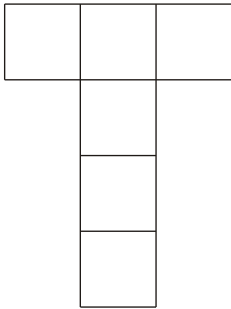

A

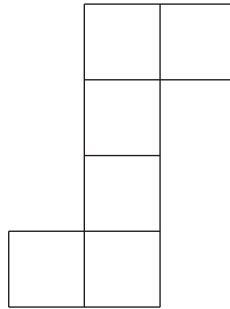

B

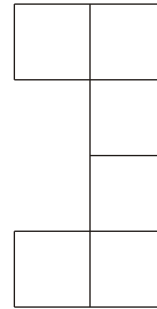

C

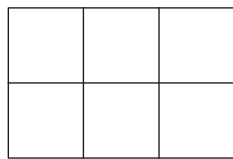

D

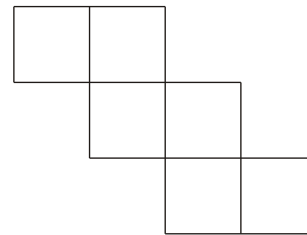

E

Answer

(Total 2 marks)

2. These are the nets of two solids.

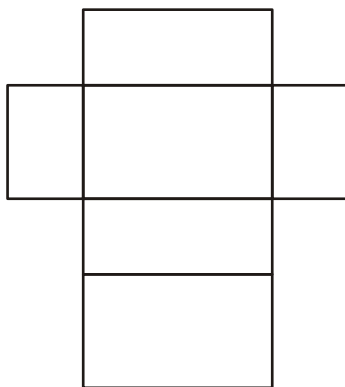

Net A

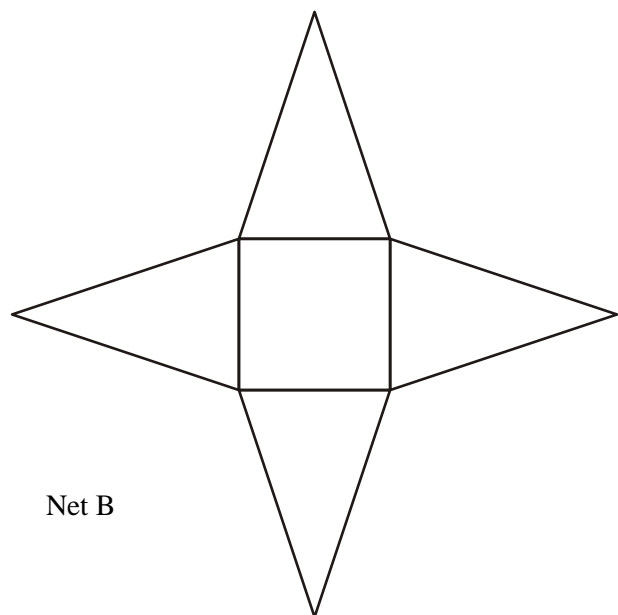

Net B

What are the names of the solids?

Answer Net A Net B

(Total 2 marks)

3. The diagram shows a cube of side 2 cm.

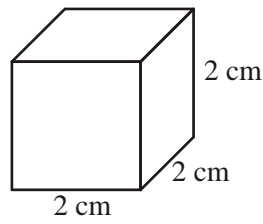

Not to scale

- (a) How many faces does a cube have?

Answer

(1)

- (b) Draw an accurate net of this cube on the grid below.

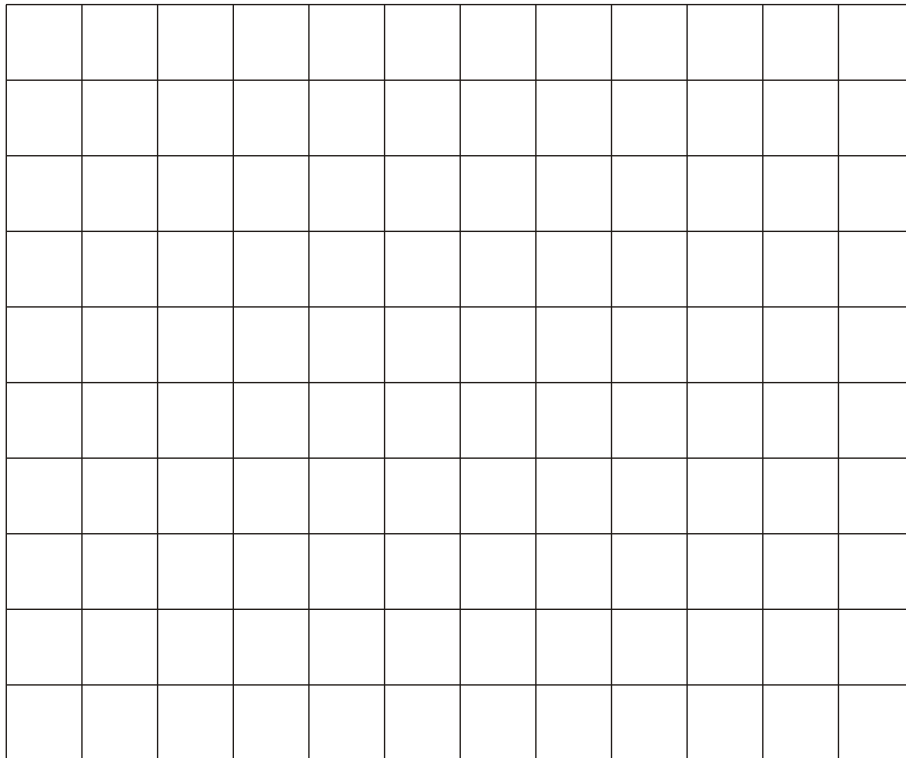

(3)

(Total 4 marks)

4. (i) Shade one more square so that the shaded shape is a net of a cube.

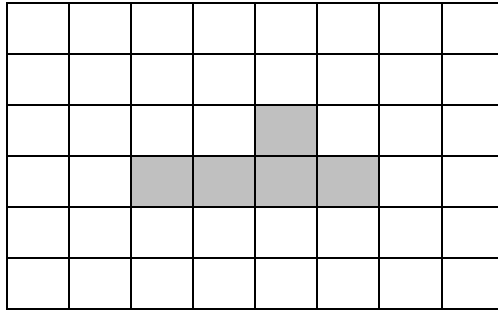

(1)

- (ii) Explain why this shape is **not** the net of a cube.

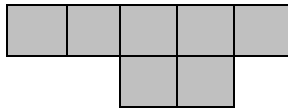

.....

.....

.....

(Total 2 marks)

5. This box has the shape of a cuboid.
It has no lid.

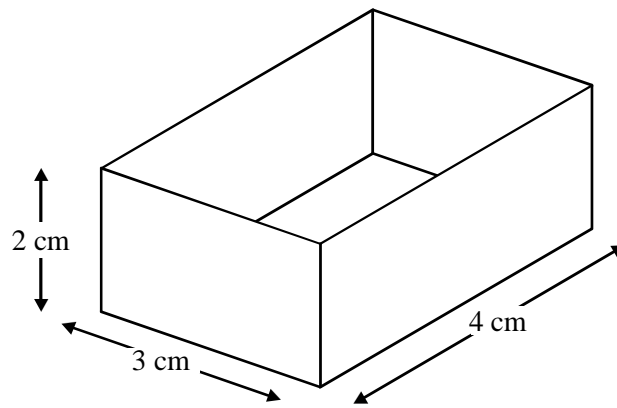

Draw an accurate net of the box.

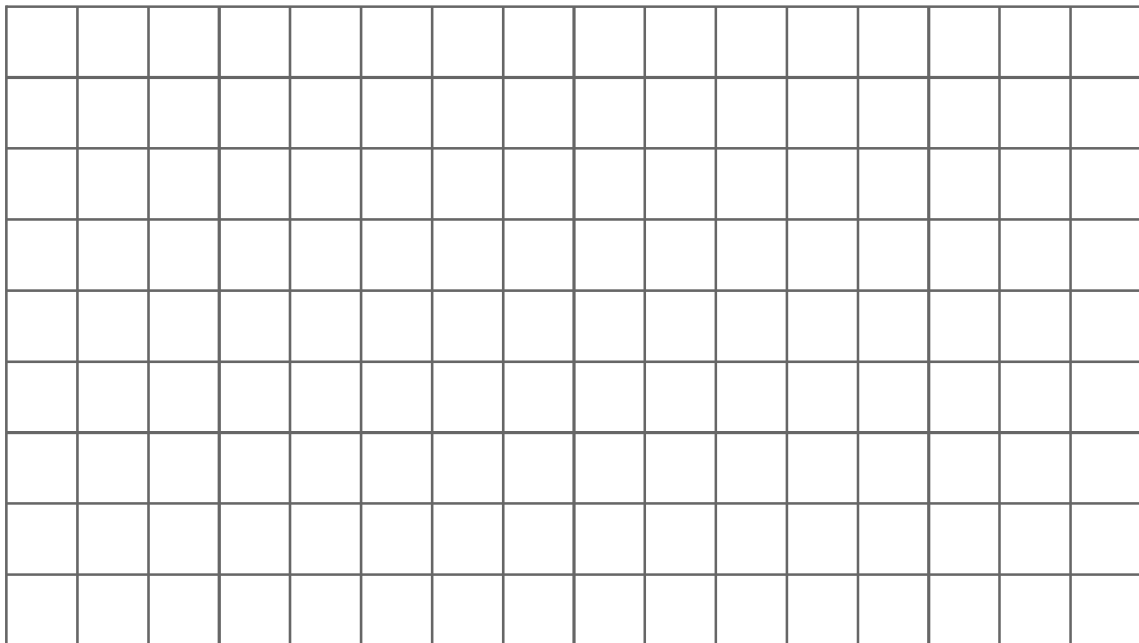

(Total 3 marks)

6. The diagram shows a cuboid of length 6 cm, width 2 cm and height 3 cm.

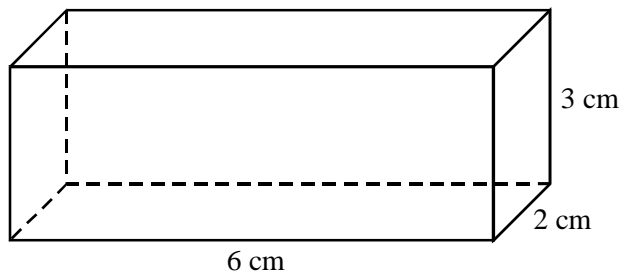

Not to scale

Draw the net of the cuboid.
The base has been drawn for you.

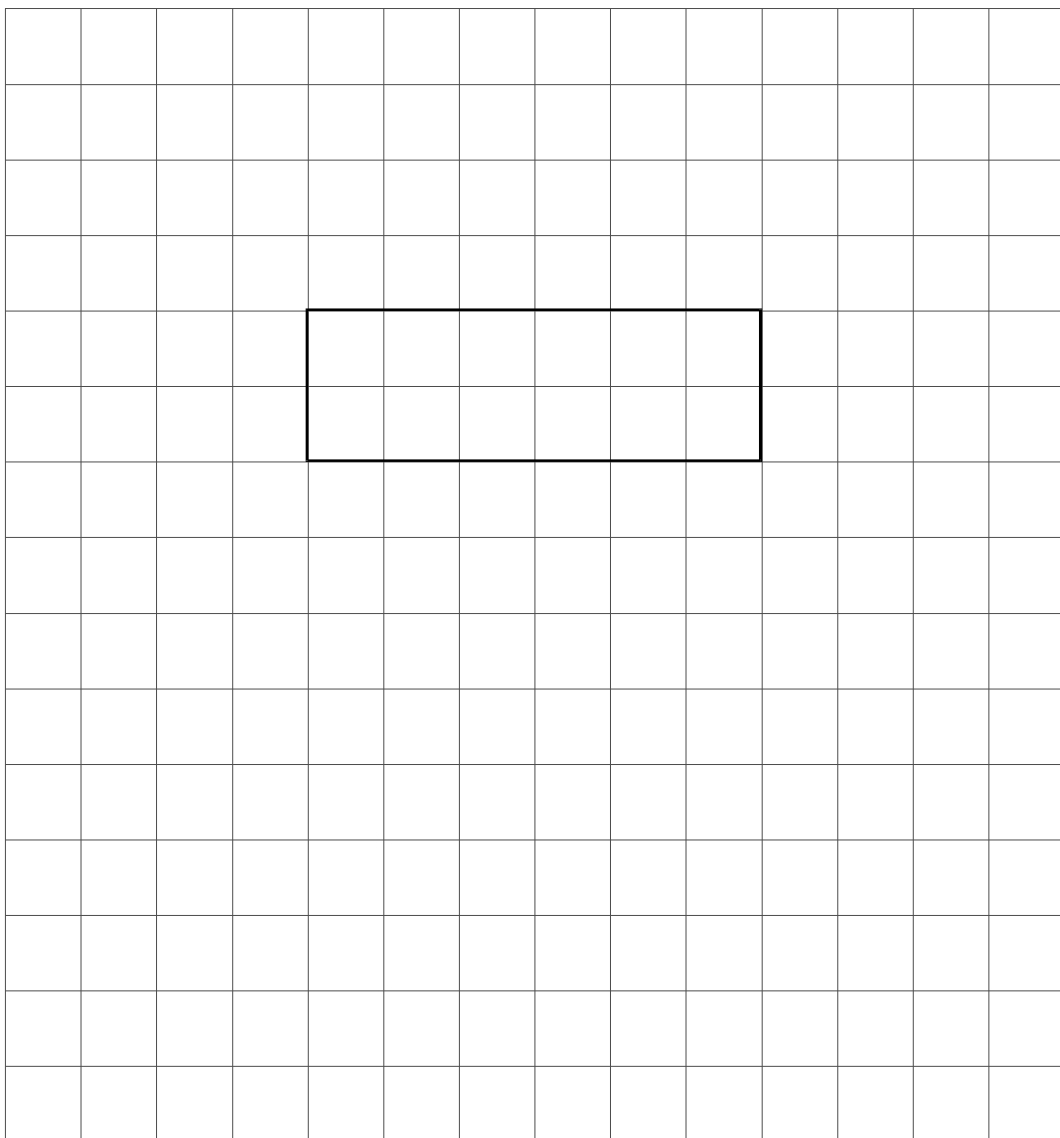

(Total 3 marks)

7. The diagram shows a cuboid

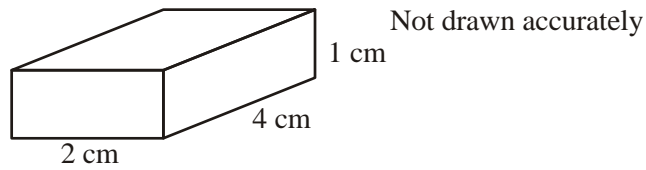

(a) How many faces does a cuboid have?

Answer

(1)

(b) Draw an accurate net of this cuboid on the grid below.

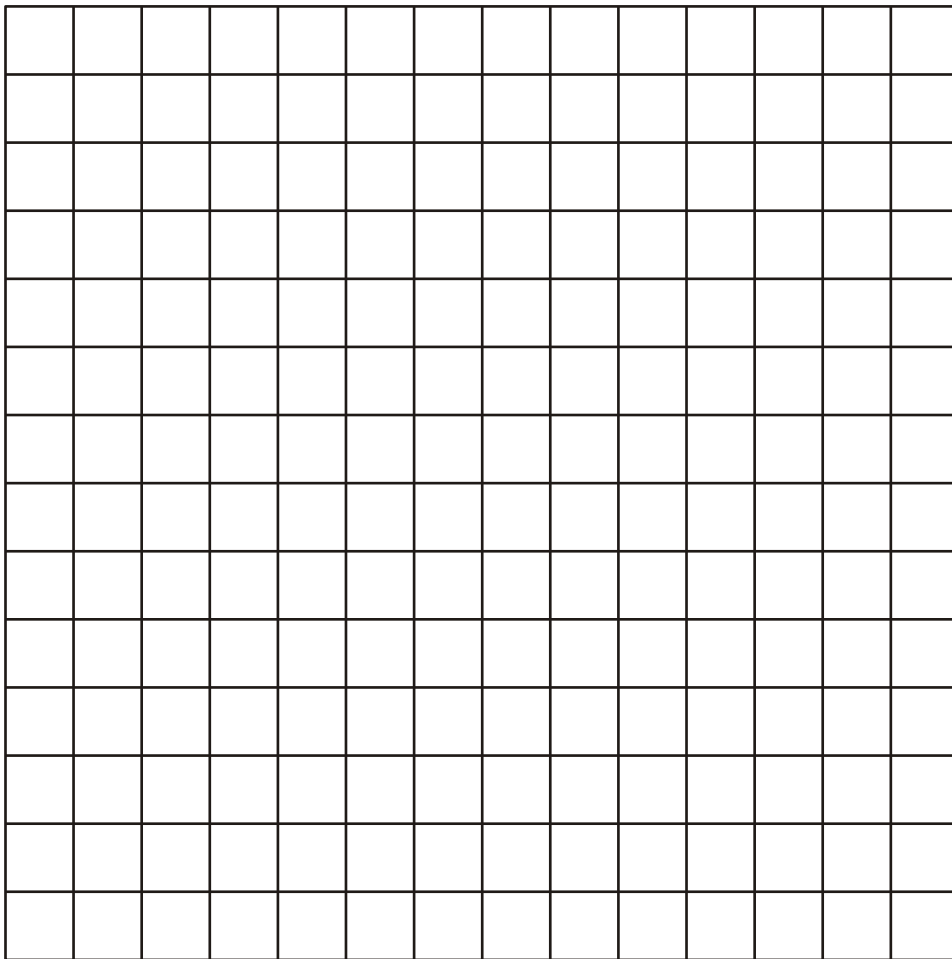

(3)

(Total 4 marks)

Success:

Target:

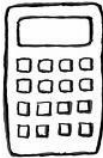

Section D **Symmetry** **Grade F**

2. The diagram shows the net of a solid.

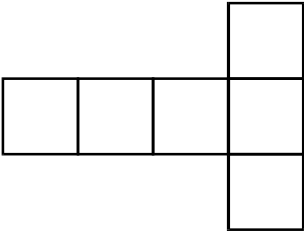

(a) What is the name of the solid?

Answer

(1)

(b) The net has one line of symmetry.
Draw the line of symmetry on the diagram.

(1)

(c) Add two squares to the diagram below so that it has rotational symmetry of order two.

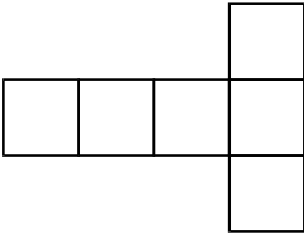

(1)(Total 3 marks)

2. (i) Shade one more square so that the shaded shape has one line of symmetry.

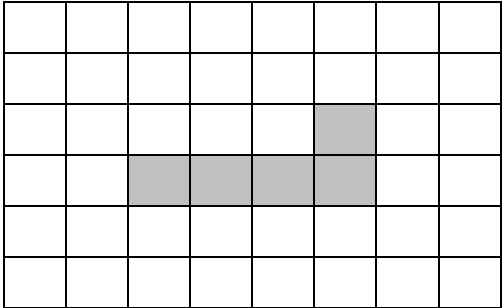

(1)

(ii) Shade one more square so that the shaded shape has rotational symmetry of order 2.

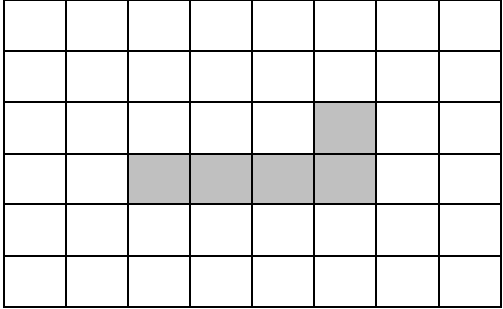

(1)
(Total 2 marks)

3. A regular hexagon is drawn below.

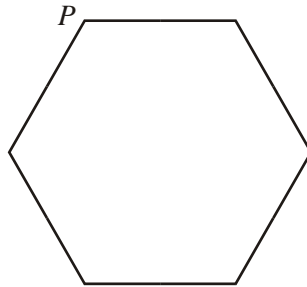

- (i) Draw the line of symmetry which passes through the point *P*. (1)
- (ii) How many lines of symmetry does a regular hexagon have?

Answer

(1)
(Total 2 marks)

4. A shape is made of 1 cm squares.

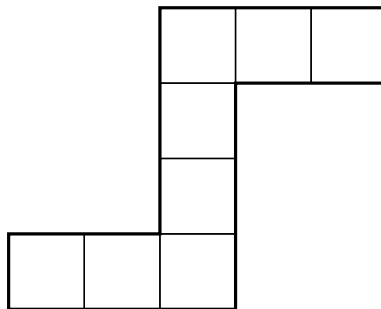

- (a) Work out the perimeter of the shape.

Answer cm

(1)

- (b) Work out the area of the shape.

Answer cm²

(1)

- (c) Write down the order of rotational symmetry of the shape.

Answer

(1)
(Total 3 marks)

5. (a) Shade **two** more squares to make a pattern with rotational symmetry of order 2 and centre **X**.

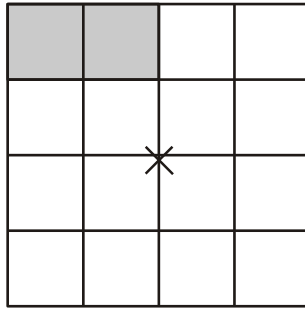

(1)

- (b) Shade **three** more squares to make a pattern with 1 line of symmetry.

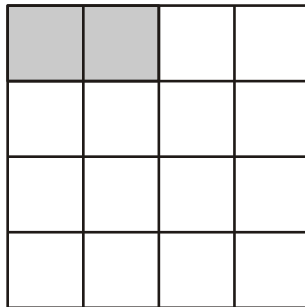

(2)

(Total 3 marks)

6. (a) A square is drawn below.

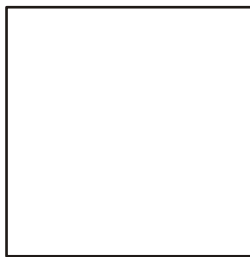

Draw all the lines of symmetry.

(2)

- (b) Three small squares are shaded in the diagram.

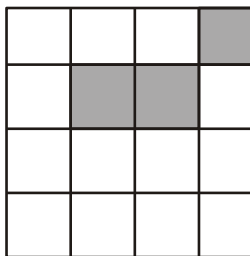

Shade in three more small squares to make a pattern with rotational symmetry order 2.

(2)

(Total 4 marks)

7. (a)

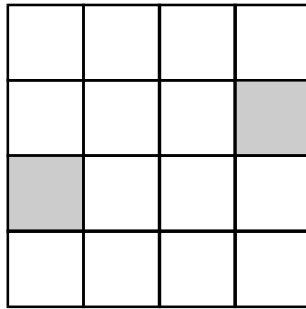

Shade in 2 more small squares to make a pattern that is symmetrical about both diagonals of the large square.

(2)

(b)

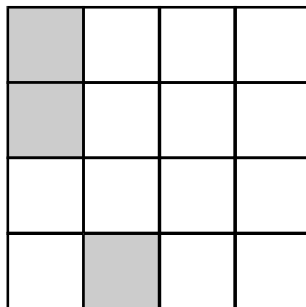

Shade in 3 more small squares to make a pattern with rotational symmetry of order 2.

(2)

(Total 4 marks)

8. Shade 9 more squares so that the grid has rotational symmetry of order 4 about centre ×

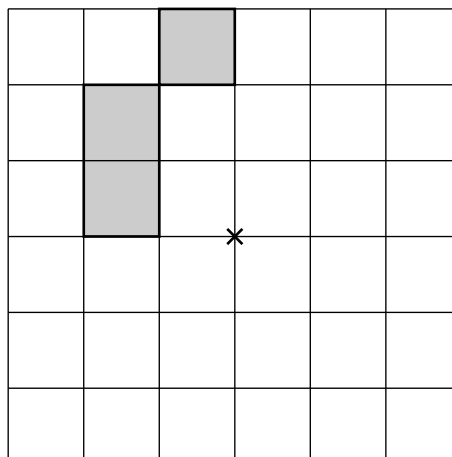

(Total 3 marks)

9. (a) A pattern has four lines of symmetry.
 Part of the pattern is shown below.
 Complete the pattern.

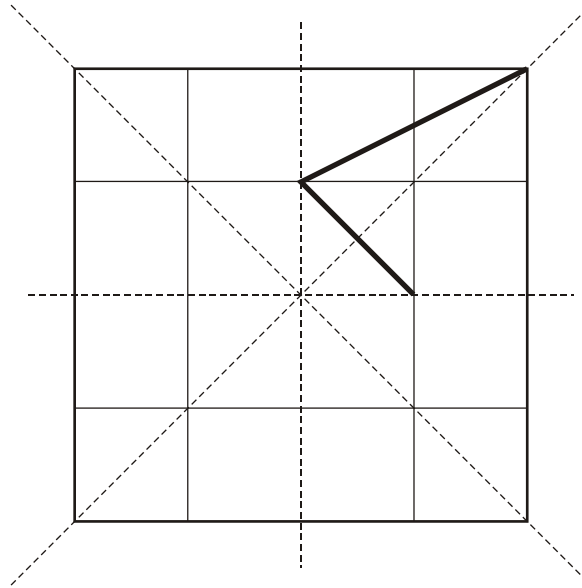

(2)

- (b) A different pattern has rotational symmetry of order 4 and no line symmetry.
 Part of the pattern is shown below.
 Complete the pattern.

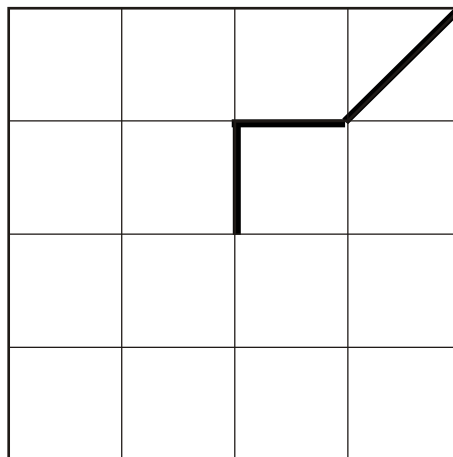

(2)
 (Total 4 marks)

10. The diagram shows an equilateral triangle made up of smaller equilateral triangles. Two of the smaller triangles are shaded.

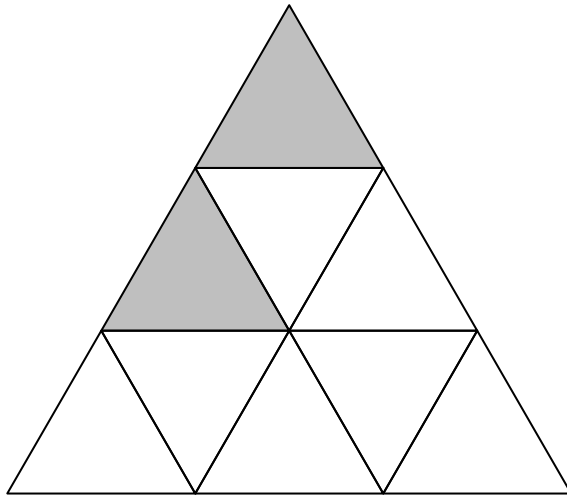

Shade **four more** smaller triangles so that the final shape has rotational symmetry of order 3.

(Total 2 marks)

11. (a) Shade **four more** triangles to make a pattern with 3 lines of symmetry.

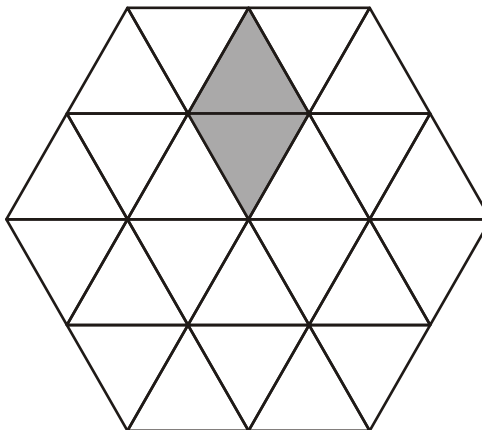

(1)

- (b) Shade **six more** triangles to make a pattern with rotational symmetry order 3.

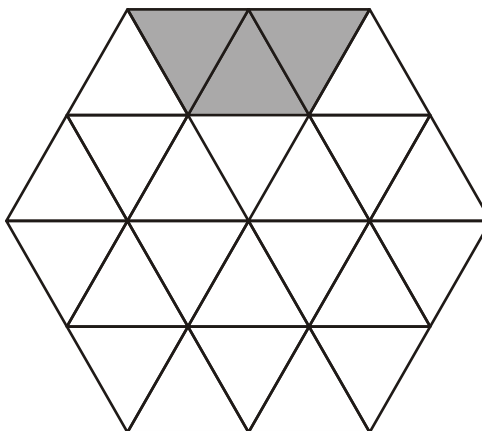

(2)

(Total 3 marks)

12. (a) This quadrilateral has **exactly** two lines of symmetry.

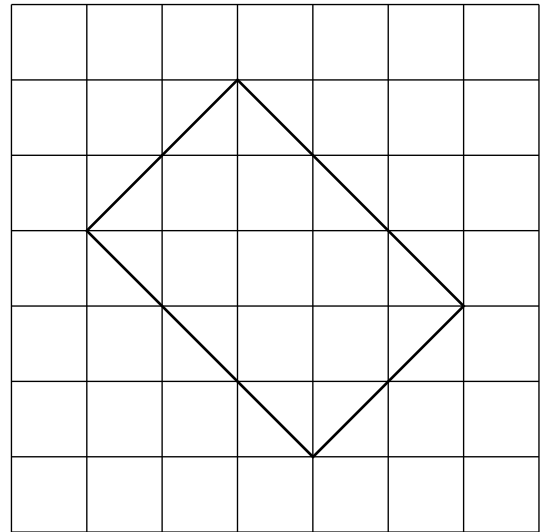

(i) Draw the lines of symmetry on the diagram.

(1)

(ii) Write down the name of this type of quadrilateral.

Answer

(1)

(b) A different type of quadrilateral also has **exactly** two lines of symmetry.

(i) Complete this quadrilateral on the grid below.

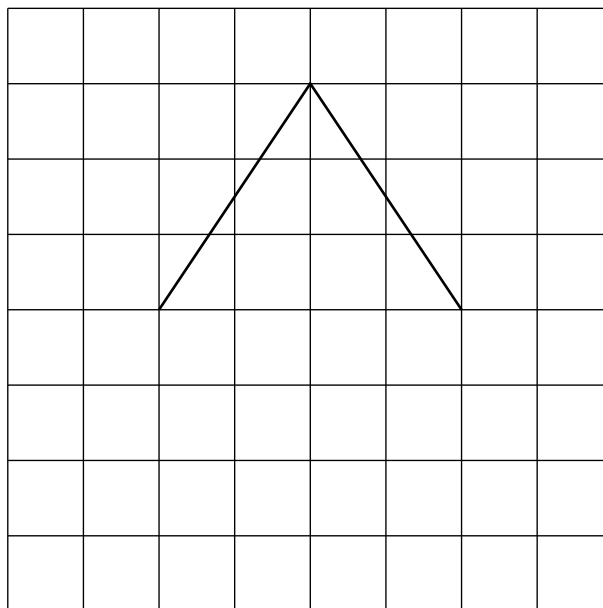

(1)

(ii) Write down the name of this type of quadrilateral.

Answer

(1)

(c) Write down **one** difference between the quadrilaterals in parts (a) and (b).

.....
.....

(1)(Total 5 marks)

13. Each diagram shows the same cuboid.
The length, width and height of the cuboid are all different.
A plane cuts each cuboid into two equal parts.

For each diagram state whether the plane is a plane of symmetry.

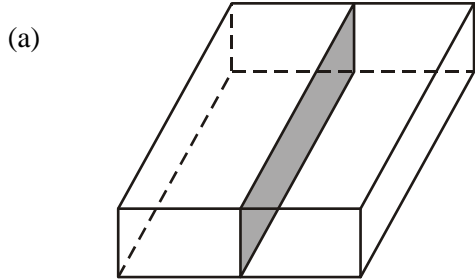

Drawn to scale

Answer

(1)

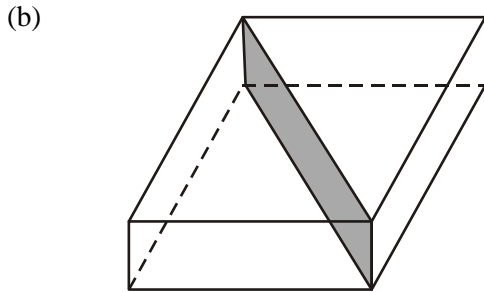

Drawn to scale

Answer

(1)

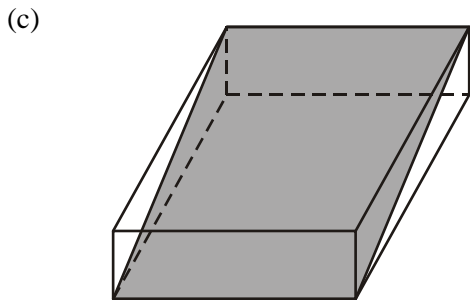

Drawn to scale

Answer

(1)

(Total 3 marks)

14. How many planes of symmetry has a cuboid?

.....
.....

Answer

(Total 2 marks)

Success:

Target: